



## Supermarket Freezer

## XS 701 E



Energy efficiency class

**C**

|             |                 |                  |          |
|-------------|-----------------|------------------|----------|
| Item number | 23420701E110000 | Taric goods code | 84185011 |
| EAN code    | 5704704013131   | QTY in 40HQ      | 39       |

### Short Description

#### Key features

- Large curved sliding glass lids
- 6 strong wire baskets
- Coated white steel inner liner
- 4 strong castors
- Bumper bars

#### Measurement Drawings

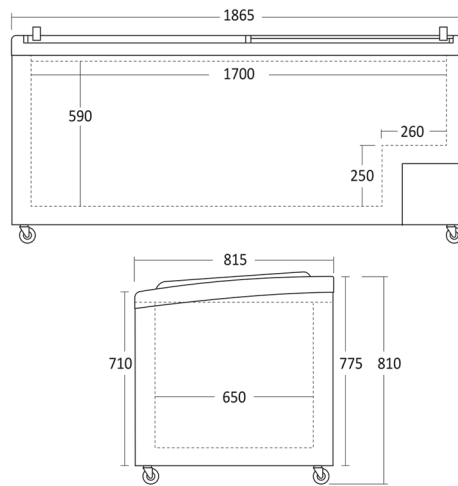

#### Dimensions and weight

|                                       |                  |
|---------------------------------------|------------------|
| Product dimensions, HxWxD, mm         | 850 x 1865 x 814 |
| Packaging dimensions, HxWxD, mm       | 895 x 1930 x 880 |
| Total packaging volume m <sup>3</sup> | 1,52             |
| Gross volume, L                       | 670              |
| Net volume, L                         | 501              |
| Gross- / Net volume, L                | 670 / 501        |
| Internal dimensions, HxWxD, mm        | 590 x 1700 x 650 |
| Gross- / Net weight, kg               | 125 / 105        |

#### Performance and consumption

|                                    |             |
|------------------------------------|-------------|
| Energy efficiency class            | C           |
| Daily Energy Consumption, kWh/24   | 4,877       |
| Annual energy cons. kWh/a          | 1780        |
| Energy Efficiency Index (EEI)      | 30,56       |
| Noise level, dB(A)                 | 48          |
| Refrigeration / freezing technique | Static      |
| Climate class                      | 4           |
| Type of refrigerant / gas gr.      | R290a / 135 |
| Temperature range °C               | -18 / -24   |
| Energy efficiency class            | C           |

#### Installation and power

|                         |           |
|-------------------------|-----------|
| Voltage / hertz, V/hz   | 230 / 50  |
| Watt / Ampere, W/A      | 420 / 2.5 |
| Length of Powercord, cm | 200       |

#### Design and comfort

|                        |                |
|------------------------|----------------|
| Controller             | Digital        |
| Control panel          | Outside        |
| Digital display        | Yes            |
| Internal light         | 1 Vertical LED |
| External thermometer   | No             |
| Reversible door        | No             |
| Handle                 | Outside        |
| Number of castors, pcs | 4 castors      |
| Lock & Key             | No             |

#### Colour and material

|                                 |               |
|---------------------------------|---------------|
| Inside Colour                   | White         |
| Colour and material of door/lid | Sliding glass |

#### Interior features

|                          |                 |
|--------------------------|-----------------|
| Number of Baskets (pcs)  | 6               |
| Basket Size (HxWxD) (mm) | 266 x 277 x 676 |
| Basket Material          | White wire      |

# scandomestic

Scandomestic A/S . Linåvej 20 . DK-8600 Silkeborg . Tel.: +45 7242 5571 . www.scandomestic.dk